

! Contact our sales office for delivery dates and prices as this is a special model.

Specialized Product **P.G.** Point to Group information

Electric Actuator: Guide Rod Type

LEYG-X245

Features

- Uses a compact guide cylinder (MGPM series) unit
- Improved performance as a stopper

LEYG25-X245
Increased by 3 times
(140 kg ← 45 kg)

LEYG32-X245
Increased by 5 times
(410 kg ← 75 kg)

LEYG40-X245
Increased by 14 times
(1100 kg ← 75 kg)

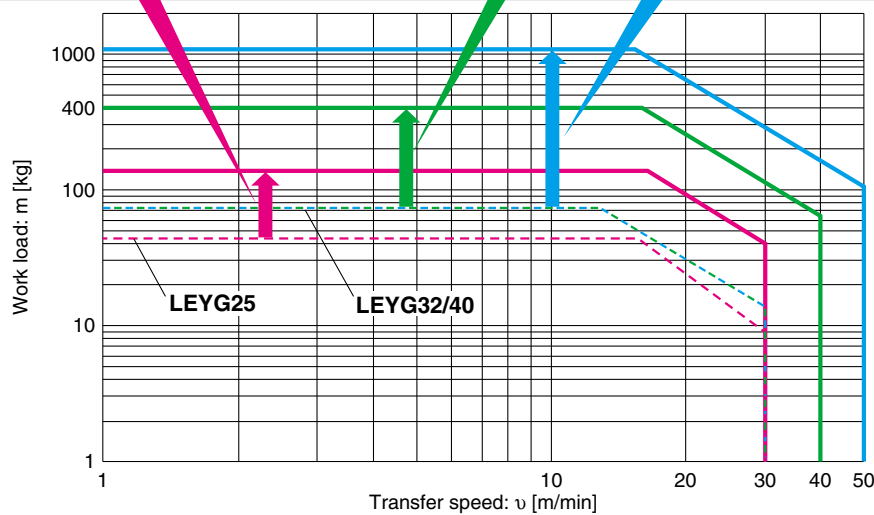

Operating range when used as a stopper



Size: 25, 32, 40
Stroke: 30, 50 mm*1

*1 Applicable stroke range:
50 mm or less

Application Examples

Best suited for applications where transferred objects are heavy and the transfer speed is fast.

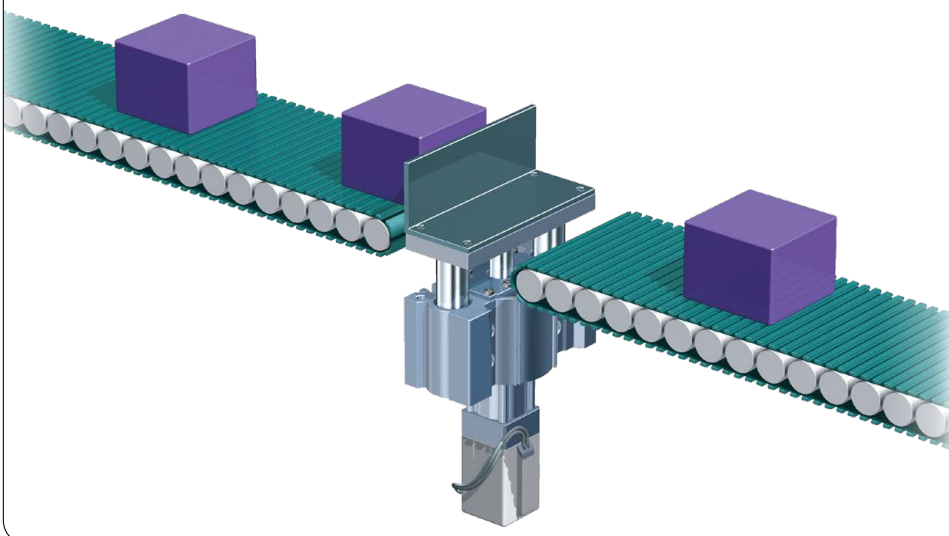

Caution

To ensure the safest possible operation of this product, please be sure to thoroughly read the "Safety Instructions" in our "Best Pneumatics" catalog before use.

How to Order

LEYG **32** MDC - **30** **C** - **S1** - X245



1 Size

25
32
40

2 Stroke

30	30 mm
50	50 mm

3 Motor option

C	With motor cover
W	With lock/motor cover

4 Actuator cable type/length

Nil	Without cable
S1	Standard cable 1.5 m
S3	Standard cable 3 m
S5	Standard cable 5 m
R1	Robotic cable (Flexible cable) 1.5 m
R3	Robotic cable (Flexible cable) 3 m
R5	Robotic cable (Flexible cable) 5 m
R8	Robotic cable (Flexible cable) 8 m* ¹
RA	Robotic cable (Flexible cable) 10 m* ¹
RB	Robotic cable (Flexible cable) 15 m* ¹
RC	Robotic cable (Flexible cable) 20 m* ¹

- *1 Produced upon receipt of order (Robotic cable only)
- *2 The standard cable should only be used on fixed parts. For use on moving parts, select the robotic cable.

5 Controller/Driver type*¹

Nil	Without controller/driver	
6N	LECP6	NPN
6P	(Step data input type)	PNP
1N	LECP1	NPN
1P	(Programless type)	PNP
MJ	LECPMJ * ²	—
	(CC-Link direct input type)	
AN	LECPA * ³	NPN
AP	(Pulse input type)	PNP

- *1 For details on controllers/drivers and compatible motors, refer to the **Web Catalog**.
- *2 Not applicable to CE
- *3 When pulse signals are open collector, order the current limiting resistor (LEC-PA-R-□) separately. (Refer to the **Web Catalog**.)

Specifications

Model		LEYG25MDC-X245	LEYG32MDC-X245	LEYG40MDC-X245			
Actuator specifications	Stroke [mm]	30, 50					
	Work load [kg]* ¹	Horizontal	LECP6	(3000 [mm/s ²])	60	60	80
			LECP1	(2000 [mm/s ²])	70	80	90
		Vertical* ²	LECPMJ	(3000 [mm/s ²])	30	40	60
			LECPA	(2000 [mm/s ²])	50	60	—
				(3000 [mm/s ²])	30	43	53
	Pushing force [N]	232 to 452		296 to 707	562 to 1058		
	Speed [mm/s]	LECP6/LECP1/LECPMJ	5 to 125		6 to 150	6 to 175	
		LECPA	5 to 125		6 to 125	6 to 75	
	Max. acceleration/deceleration [mm/s ²]	3000					
	Pushing speed [mm/s]	35 or less		30 or less	30 or less		
	Positioning repeatability [mm]	±0.02					
	Lost motion [mm]	0.15 or less					
	Screw lead [mm]	3	4	4			
Impact/Vibration resistance [m/s ²]	50/20						
Actuation type	Ball screw						
Guide type	Sliding bearing						
Operating temperature range [°C]	5 to 40						
Operating humidity range [%RH]	90 or less (No condensation)						
Electric specifications	Motor size	□42	□56.4	□56.4			
	Motor type	Step motor (Servo/24 VDC)					
	Encoder	Incremental A/B phase (800 pulse/rotation)					
	Rated voltage [V]	DC24 ±10%					
	Power consumption [W]	40	50	50			
	Standby power consumption when operating [W]	15	48	48			
	Max. instantaneous power consumption [W]	48	104	106			
Lock unit specifications	Type	Non-magnetizing lock					
	Holding force [N]	294	421	519			
	Power consumption [W]	5					
	Rated voltage [V]	DC24 ±10%					
International standards	CE marking						

- *1 The maximum value of the work load when the acceleration/deceleration in brackets () is applied
- *2 The guide weight is not considered in the vertical work load. Add [Guide weight] to the vertical work load, and then refer to the "Speed - Vertical Work Load Graph" of the LEY series in the **Web Catalog**.
- *3 For other precautions, refer to the LEY series in the **Web Catalog**.

Weight of Guide Drive

Stroke	Size	Weight [kg]		
		25	35	40
30		0.9	1.6	3.1
50		1	1.8	3.3

Vertical mounting

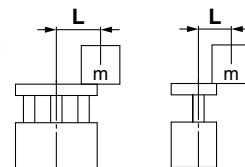

Size	Eccentric distance: L [mm]	Load mass [kg]			
		10	50	100	200
25	Load mass [kg]	30	30	21.9	10.9
32		43	43	36	18
40		53	53	49.2	25

- * For the load mass, subtract the guide weight according to the stroke.

Horizontal mounting

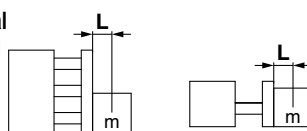

Size	Stroke [mm]	Load mass [kg]	
		30	50
25	L = 50 mm	12.7	11.1
	L = 100 mm	9.5	8.5
32	L = 50 mm	19.1	16.7
	L = 100 mm	14.4	12.9
40	L = 50 mm	22.5	19.9
	L = 100 mm	17.2	15.5

Stopper direction

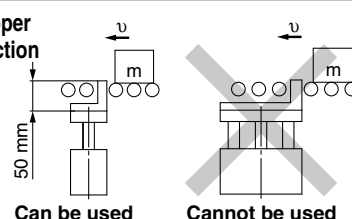

Dimensions

LEYG25/32M-X245

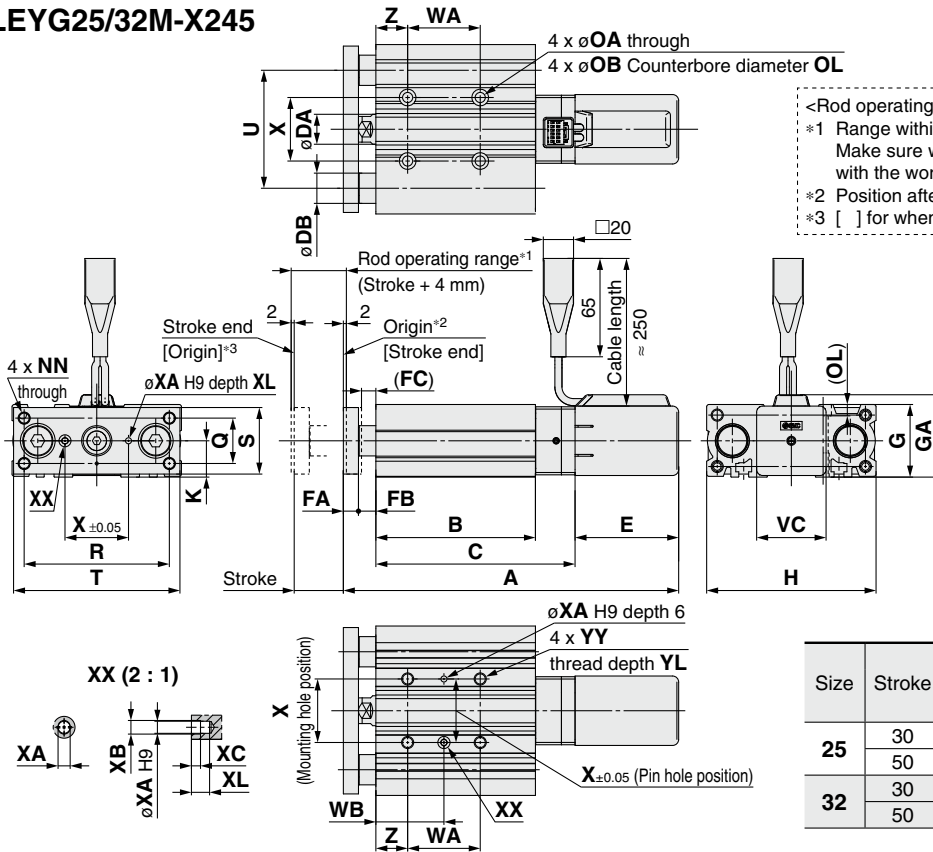

Size	DA	DB	FA	FB	FC	G	GA	H
25	20	20	10	11.5	9.5	48	54.45	112
32	25	25	12	15.5	13.5	64	69.45	148

Size	K	NN	OA	OB	OL	Q	R
25	24	M8 x 1.25	6.7	11	7.5	30	96
32	32	M10 x 1.5	8.6	14	9	40	130

Size	S	T	U	VC	WA	WB	X
25	44	110	78	45.9	48	45	42
32	60	146	110	59.9	48	48	66

Size	XA	XB	XC	XL	YY	YL	Z
25	4	4.5	3	6	M8 x 1.25	16	21
32	5	6	4	8	M10 x 1.5	20	24

Size	Stroke	A		B	C	E	
		With motor cover	With lock/motor cover			With motor cover	With lock/motor cover
25	30	221.7	262.2	105.5	131.7	68.5	109
	50	241.7	282.2	125.5	151.7		
32	30	243.2	286.2	110	139.2	73.5	116.5
	50	263.2	306.2	130	159.2		

LEYG40M-X245

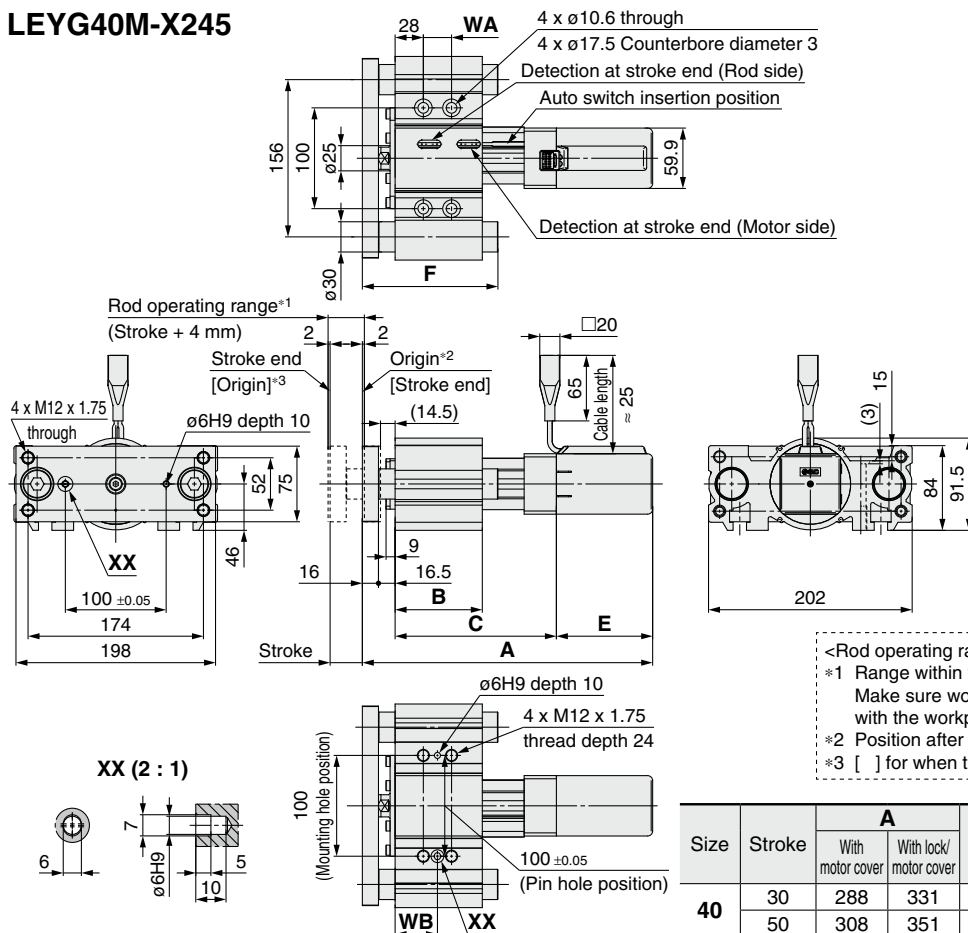

Size	Stroke	A		B	C	WA	E		F	WB
		With motor cover	With lock/motor cover				With motor cover	With lock/motor cover		
40	30	288	331	86.5	160	28	95.5	138.5	134.5	42
	50	308	351	106.5	180	52			154.5	54

Caution

1. Workpiece collision in series with the guide cannot be permitted.

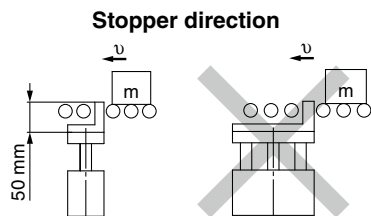

2. The manufacturable stroke range is 30 to 300 mm. Please contact SMC for strokes other than 30 and 50. When using as a stopper, select a model with a stroke of 50 mm or less.

3. Make sure that the cylinder mounting surface has a flatness of 0.02 mm or less.

If the flatness of the workpieces and brackets mounted on the plate are not appropriate, sliding resistance may increase. If it is difficult to maintain a flatness of 0.02 mm or less, put a thin shim ring (provided by the customer) between the plate and the workpiece mounting surface to prevent the sliding resistance from increasing.

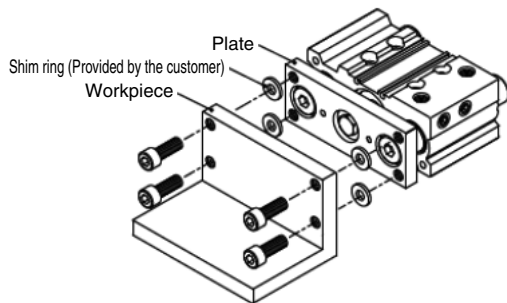

4. Do not scratch or gouge the sliding portion of the piston rod and the guide rod.

Doing so may cause a malfunction.

5. Do not dent or scratch the mounting surface of the body and the plate.

This may cause a decrease in the flatness of the mounting surface, which will cause an increase in sliding resistance.

6. Do not operate the actuator in a state where lateral loads are applied.

The actuator may not operate due to the friction force generated between the conveyor and the transferred object.

Regarding this product, unless otherwise noted along with a separate contract or agreement within the Product Specifications, the safety instructions specified in the catalog are applied.

Please contact your local SMC Sales office for further details.