

# 带Uni-螺纹 - 快换管接头 速度控制阀 AS 系列

螺纹拧入作业时间只要 $\frac{1}{3}$ 的新型管螺纹

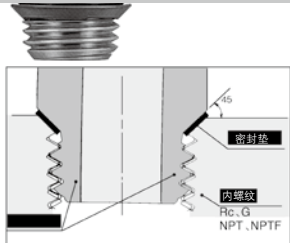

## Uni螺纹牙形状

内螺纹的倒角面作为密封面，在不锈钢片的两面，有一层NBR密封材料作为密封垫。尽管内螺纹种类不同，螺纹直径不同，公差的变化及倒角大小的不同，该密封构造都能实现密封。

(带倒角的通常使用的内螺纹都可使用。)

适合各种规格管内螺纹 (Rc, G, NPT, NPTF), 具有独特的螺纹构造

采用密封垫密封方式, 故螺纹拧入时间大大缩短



## JIS图符号

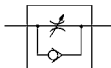

主体上表示的流动方向的记号

	排气节流型	进气节流型
记号		
JIS图符号		

## 型号

品种		连接螺纹 Uni	适合管子外径													
弯头型	万向型		米制						英制							
			3.2	4	6	8	10	12	1/8	5/32	3/16	1/4	5/16	3/8	1/2	
AS22□1F-U01	AS23□1F-U01	1/8	●	●	●	●	●	●	●	●	●	●	●	●	●	●
AS22□1F-U02	AS23□1F-U02	1/4	●	●	●	●	●	●	●	●	●	●	●	●	●	●
AS32□1F-U02	AS33□1F-U02	1/4		●	●	●	●	●					●	●	●	●
AS32□1F-U03	AS33□1F-U03	3/8			●	●	●	●					●	●	●	●
AS42□1F-U04	AS43□1F-U04	1/2					●	●							●	●

注1) ※仅有弯头型。

注2) □内为控制方式(0: 排气节流, 1: 进气节流)

注3) 排气节流式和进气节流式是通过锁母进行外观识别

排气节流式为无电解镀铬, 进气节流式为黑色铬酸锌。

注4) ● 标准品为无电解镀铬。

## 规格

使用流体	空气
最高使用压力	1MPa
最低使用压力	0.1MPa
保证耐压力	1.5MPa
环境温度及使用流体温度	-5~60°C(但未冻结)
适合管子材质 <sup>注1)</sup>	尼龙, 软尼龙, 聚氨酯
安装螺纹	Uni螺纹
螺纹部的密封	密封垫
可选项	六角锁母, 无电解镀铬 <sup>注2)</sup>

注1) 软尼龙、聚氨酯应注意最高使用压力。

(详见P.411, 412。)

注2) 黄铜件全是无电解镀铬。

## 流量及声速流导

型号		AS22□1F-U01 AS23□1F-U02		AS22□1F-U02 AS23□1F-U02		AS32□1F AS33□1F		AS42□1F-U04 AS43□1F-U04			
管子外径	米制	φ3.2, φ4	φ6, φ8, φ4	φ4	φ6, φ8, φ10	φ6	φ8, φ10, φ12	φ10	φ12		
	英制	1/8", 5/32"	3/16", 1/4", 5/16"	1/8"	3/16", 1/4", 5/16", 3/8"	1/4"	5/16", 3/8"	3/8"	1/2"		
控制流动 自由流动	流量L/min (ANR)	180	230	260	390	460	660	790	920	1580	1710
	声速流导 dm <sup>3</sup> /(s·bar)	0.5	0.64	0.72	1.1	1.3	1.8	2.2	2.6	4.4	4.8
临界压力比	控制流动	0.25		0.3		0.25		0.25			
	自由流动	0.2		0.3		0.2		0.3			

注) 流量是压力0.5MPa、温度20°C时的值。

型号表示方法

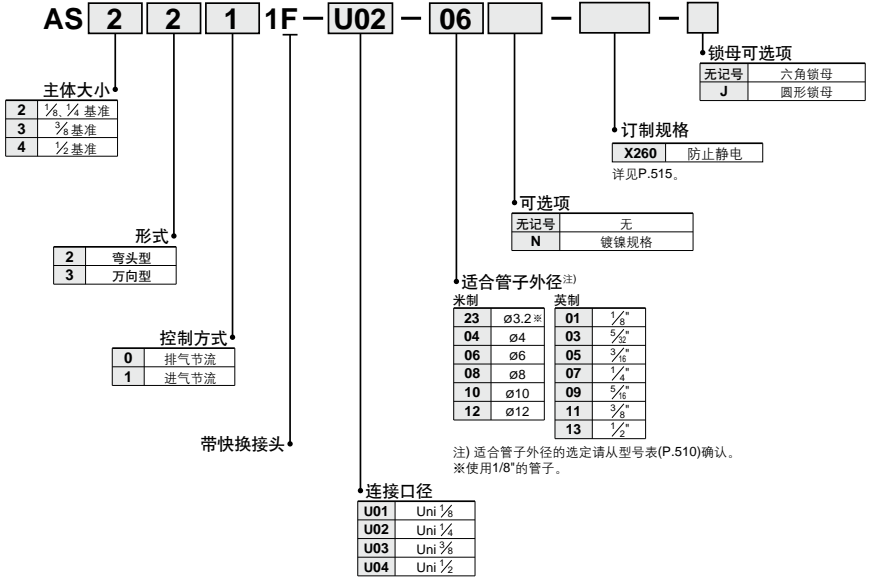

- AS
- TMH
- ASD
- AS
- AS-FE KE
- AS-FG
- AS-FP
- AS-FM
- AS-D AS-T
- ASP
- ASN
- AQ
- ASV
- AK
- VCHC
- ASS
- ASR ASQ

针阀/流量特性

注) 流量特性为代表性。

AS2201F-U01, AS2211F-U01  
AS2301F-U01, AS2311F-U01

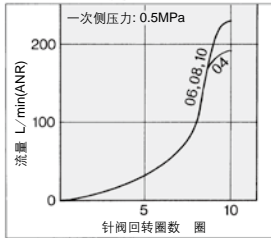

AS2201F-U02, AS2211F-U02  
AS2301F-U02, AS2311F-U02

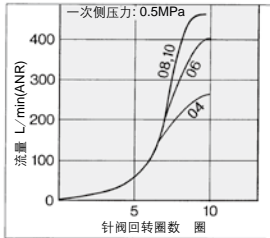

AS3201F, AS3211F  
AS3301F, AS3311F

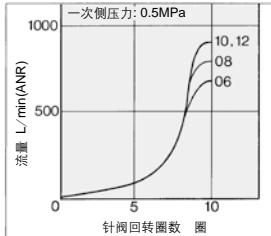

AS4201F, AS4211F  
AS4301F, AS4311F

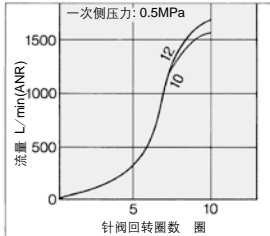

# AS 系列

## 结构图 / 零部件清单

### 弯头型 排气节流

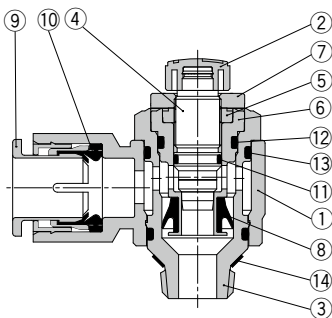

### 进气节流

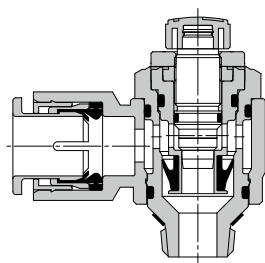

### 万向型 排气节流

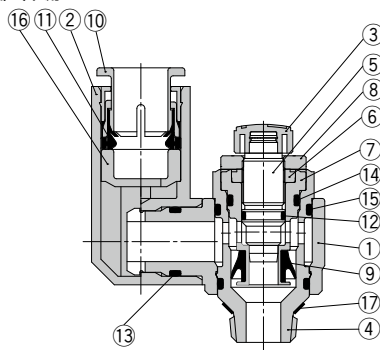

### 进气节流

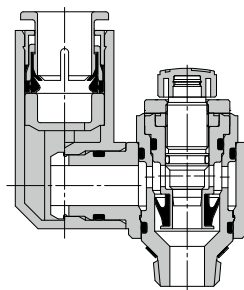

### 构成零件 / 弯头型

序号	名称	材质	备注
1	阀体A	PBT	
2	手柄	PBT	
3	阀体B	黄铜	无电解镀锌
4	针阀	黄铜	无电解镀锌
5	针阀导座	黄铜	无电解镀锌
6	护环	黄铜	注1)
7	锁母	钢注2)	排气节流 铬酸锌注3)
			进气节流 黑色铬酸锌
8	U形密封圈	HNBR	
9	释放套	-	
10	密封圈	NBR	
11	O形圈	NBR	
12	O形圈	NBR	
13	O形圈	NBR	
14	密封垫	NBR, 不锈钢	

注1) AS22□1F-U01, AS32□1F-U02为无电解镀锌。  
 注2) 锁母可选项-J(圆形)的材质为黄铜, 仅AS22□1F是钢。  
 注3) 锁母可选项-J(圆形)的表面处理为无电解镀锌。

### 构成零件 / 万向型

序号	名称	材质	备注
1	阀体A	PBT	
2	弯头阀体	PBT	
3	手柄	PBT	
4	阀体B	黄铜	无电解镀锌
5	针阀	黄铜	无电解镀锌
6	针阀导座	黄铜	无电解镀锌
7	护环	黄铜	注1)
8	锁母	钢注2)	排气节流 铬酸锌注3)
			进气节流 黑色铬酸锌
9	U形密封圈	HNBR	
10	释放套	-	
11	密封圈	NBR	
12	O形圈	NBR	
13	O形圈	NBR	
14	O形圈	NBR	
15	O形圈	NBR	
16	衬套	-	
17	密封垫	NBR, 不锈钢	

注1) AS22□1F-U01, AS32□1F-U02为无电解镀锌。  
 注2) 锁母可选项-J(圆形)的材质为黄铜, 仅AS23□1F是钢。  
 注3) 锁母可选项-J(圆形)的表面处理为无电解镀锌。



〈米制〉弯头型

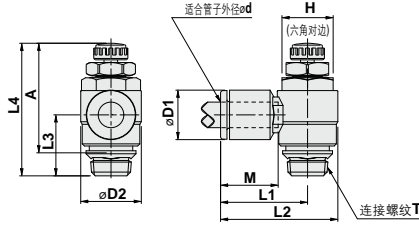

型号	适合管子 外径eD(mm)	T Uni螺纹	H	eD1	eD2	L1	L2	L3	L4 <sup>注1)</sup>		A <sup>注2)</sup>		M	质量 g
									Max.	Min.	Max.	Min.		
AS22□1F-U01-23	3.2	1/8	12	7.8	14.2	20.8	27.9	14.3	36.1	31.1	30.5	25.5	14.5	17
AS22□1F-U01-04	4			8.9		21.1	28.2						17	
AS22□1F-U01-06	6			11.0		22.5	29.6						15.5	17
AS22□1F-U01-08	8			15.2		25.3	32.4						18.5	19
AS22□1F-U01-10	10		18.5	33.1	40.2	15.0	21	21						
AS22□1F-U02-04	4	1/4	17	8.9	18.5	23.3	32.5	17.2	39.4	34.4	32.0	26.6	14.5	32
AS22□1F-U02-06	6			11.0		23.9	33.1						15.5	32
AS22□1F-U02-08	8			15.2		27.2	36.4						18.5	34
AS22□1F-U02-10	10			18.5		35.3	44.5						21	36
AS32□1F-U02-06	6	1/4	19	11.0	23.0	26.4	37.9	20.3	45.9	40.9	38.1	33.1	17	53
AS32□1F-U02-08	8			15.2		29.5	41.0						18.5	55
AS32□1F-U02-10	10			18.5		31.8	43.3						21	57
AS32□1F-U02-12	12			20.9		32.8	44.3						22	59
AS32□1F-U03-06	6	3/8	19	11.0	23.0	26.4	37.9	19.4	45.0	40.0	37.6	32.6	17	53
AS32□1F-U03-08	8			15.2		29.5	41.0						18.5	55
AS32□1F-U03-10	10			18.5		31.8	43.3						21	57
AS32□1F-U03-12	12			20.9		32.8	44.3						22	59
AS42□1F-U04-10	10	1/2	24	18.5	28.6	33.6	47.9	22.4	54.6	47.1	44.5	37.0	21	94
AS42□1F-U04-12	12			21.7		35.2	49.5						22	95

注1) 参考尺寸  
注2) Uni螺纹拧入后的参考尺寸



〈米制〉万向型

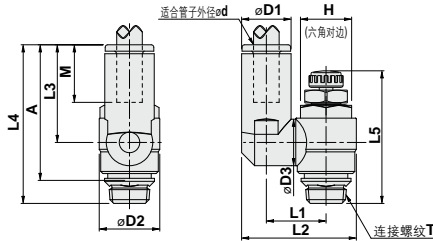

型号	适合管子 外径eD(mm)	T Uni螺纹	H	eD1	eD2	eD3	L1	L2	L3	L4	L5 <sup>注1)</sup>		A <sup>注2)</sup>		M	质量 g
											Max.	Min.	Max.	Min.		
AS23□1F-U01-23	3.2	1/8	12	7.8	14.2	9.3	13.4	24.8	18.9	33.2	36.1	31.1	30.5	25.5	14.5	17
AS23□1F-U01-04	4			8.9		10.9	14.5	27.1	20.6	34.9					17	
AS23□1F-U01-06	6			11.0		12.9	16.2	30.9	24.7	38.2					15.5	18
AS23□1F-U01-08	8			15.2		12.9	16.2	30.9	24.7	38.2					18.5	21
AS23□1F-U02-04	4	1/4	17	8.9	18.5	9.3	15.6	29.2	18.9	36.1	39.4	34.4	32.0	26.6	14.5	32
AS23□1F-U02-06	6			11.0		10.9	16.7	31.4	20.6	37.8					15.5	33
AS23□1F-U02-08	8			15.2		12.9	18.3	35.2	24.4	40.8					18.5	36
AS23□1F-U02-10	10			18.5		12.9	19.6	38.1	26.8	43.2					21	40
AS33□1F-U02-06	6	1/4	19	11.0	23.0	10.9	18.9	35.9	20.6	42.5	45.9	40.9	38.1	33.1	17	54
AS33□1F-U02-08	8			15.2		12.9	20.6	39.7	24.4	43.7					18.5	57
AS33□1F-U02-10	10			18.5		12.9	22.5	43.3	28.3	48.6					21	61
AS33□1F-U02-12	12			20.9		12.9	23.5	45.5	29.3	49.6					22	63
AS33□1F-U03-06	6	3/8	19	11.0	23.0	10.9	18.9	35.9	20.6	41.6	45.0	40.0	37.6	32.6	17	54
AS33□1F-U03-08	8			15.2		12.9	20.6	39.7	24.4	42.8					18.5	57
AS33□1F-U03-10	10			18.5		12.9	22.5	43.3	28.3	47.7					21	61
AS33□1F-U03-12	12			20.9		12.9	23.5	45.5	29.3	48.7					22	63
AS43□1F-U04-10	10	1/2	24	18.5	28.6	16.2	25.3	48.9	28.3	50.7	54.6	47.1	44.5	37.0	21	98
AS43□1F-U04-12	12			21.7		19.4	26.8	51.6	30.8	53.2					22	100

注1) 参考尺寸  
注2) Uni螺纹拧入后的参考尺寸

# AS 系列



〈英制〉弯头型

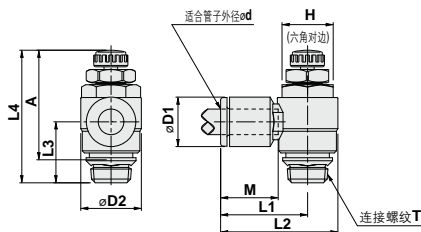

型号	适合管子外径 d	T Uni螺纹	H	øD1	øD2	L1	L2	L3	L4 <sup>注1)</sup>		A <sup>注2)</sup>		M	质量 g
									Max.	Min.	Max.	Min.		
AS22□1F-U01-01	1/8"	1/8	12	7.8	14.2	20.8	27.9	14.3	36.1	31.1	30.5	25.5	14.5	17
AS22□1F-U01-03	5/16"			8.9		21.1	28.2						17	
AS22□1F-U01-05	3/8"			11.4		23.1	30.2						16.5	
AS22□1F-U01-07	1/4"			13.2		23.9	31.0						17	
AS22□1F-U01-09	5/16"	1/4	17	15.2	18.5	25.3	32.4	17.2	39.4	34.4	32.0	26.6	18.5	19
AS22□1F-U02-03	5/16"			8.9		23.3	32.5						14.5	
AS22□1F-U02-05	3/8"			11.4		24.9	34.2						16.5	
AS22□1F-U02-07	1/4"			13.2		25.2	34.5						17	
AS22□1F-U02-09	5/16"	3/8	19	15.2	23.0	27.2	36.4	19	45.9	40.9	38.1	33.1	18.5	19
AS22□1F-U02-11	3/8"			17.9		35.3	44.5						21	
AS32□1F-U02-07	1/4"			13.2		27.8	39.3						17	
AS32□1F-U02-09	5/16"			15.2		29.5	41.0						18.5	
AS32□1F-U02-11	3/8"	1/2	24	17.9	18.6	31.8	43.3	22.4	54.6	47.1	44.5	37.0	21	24
AS32□1F-U03-07	1/4"			13.2		27.8	39.3						17	
AS32□1F-U03-09	5/16"			15.2		29.5	41.0						18.5	
AS32□1F-U03-11	3/8"			17.9		31.8	43.3						21	
AS42□1F-U04-11	3/8"	1/2	24	17.9	18.6	33.6	47.9	22.4	54.6	47.1	44.5	37.0	21	24
AS42□1F-U04-13	1/2"			21.4		35.2	49.5						22	

注1) 参考尺寸。  
注2) Uni螺纹的螺纹拧入后的参考尺寸



〈英制〉万向型

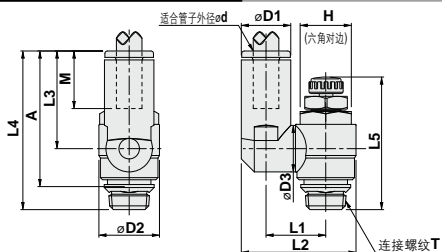

型号	适合管子外径 d	T Uni螺纹	H	øD1	øD2	øD3	L1	L2	L3	L4	L5 <sup>注1)</sup>		A <sup>注2)</sup>		M	质量 g				
											Max.	Min.	Max.	Min.						
AS23□1F-U01-01	1/8"	1/8	12	7.8	14.2	9.3	13.4	24.8	18.9	33.2	36.1	31.1	30.5	25.5	14.5	17				
AS23□1F-U01-03	5/16"			8.9											13.4	27.0	21.5	35.9	17	
AS23□1F-U01-05	3/8"			11.4											14.2	27.0	21.5	35.9	16.5	
AS23□1F-U01-07	1/4"			13.2											11.4	15.2	28.9	22.3	36.3	17
AS23□1F-U01-09	5/16"	1/4	17	15.2	18.5	12.9	16.2	30.9	24.7	38.2	39.4	34.4	32.0	26.6	18.5	21				
AS23□1F-U02-03	5/16"			8.9											9.3	15.6	29.2	18.9	36.1	14.5
AS23□1F-U02-05	3/8"			11.4											10.3	16.4	31.1	21.5	38.8	16.5
AS23□1F-U02-07	1/4"			13.2											11.4	17.4	33.2	22.3	39.5	17
AS23□1F-U02-09	5/16"	3/8	19	15.2	23.0	12.9	20.6	39.7	24.4	43.7	45.9	40.9	38.1	33.1	18.5	19				
AS23□1F-U02-11	3/8"			17.9											12.9	18.3	35.2	24.4	40.8	18.5
AS33□1F-U02-07	1/4"			13.2											11.4	19.6	37.7	22.3	44.2	17
AS33□1F-U02-09	5/16"			15.2											12.9	20.6	39.7	24.4	43.7	18.5
AS33□1F-U02-11	3/8"	1/2	24	17.9	28.6	16.2	22.5	42.9	28.3	48.6	54.6	47.1	44.5	37.0	21	24				
AS33□1F-U03-07	1/4"			13.2											11.4	19.6	37.7	22.3	43.3	17
AS33□1F-U03-09	5/16"			15.2											12.9	20.6	39.7	24.4	42.8	18.5
AS33□1F-U03-11	3/8"			17.9											16.2	22.5	42.9	28.3	47.7	21
AS43□1F-U04-11	3/8"	1/2	24	17.9	28.6	16.2	25.3	48.6	28.3	50.7	54.6	47.1	44.5	37.0	21	24				
AS43□1F-U04-13	1/2"			21.7											19.4	26.8	52.5	30.8	53.2	22

注1) 参考尺寸。  
注2) Uni螺纹的螺纹拧入后的参考尺寸

# AS 系列 订制规格

详细尺寸·规格及交货期由本公司确认。



防静电

X260

## 型号

型号	适合管子外径			
	米制尺寸			
	4	6	8	10
AS22□1F-U01	●	●	●	●
AS22□1F-U02	●	●	●	●
AS32□1F-U03		●	●	

注1) 为无电解锁母。

## 型号表示方法

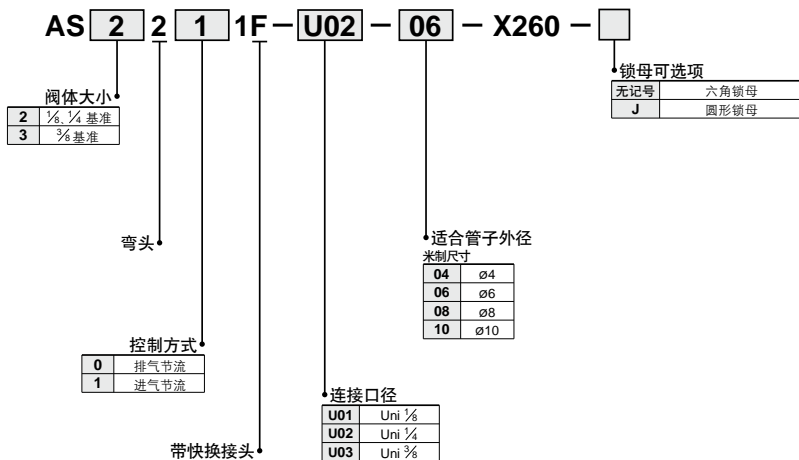

AS

TMH

ASD

AS

AS-FE  
KE

AS-FG

AS-FP

AS-FM

AS-D  
AS-T

ASP

ASN

AQ

ASV

AK

VCHC

ASS

ASR  
ASQ